



www.wunder.it

**PROFESSIONAL ELECTRONIC MDD SCALE
MOD. RB, RB-L, RB CABLE**



Read this manual carefully before using the instrument

INDEX

1. GENERAL RULES.....	2
2. SAFETY.....	3
3. INDICATOR.....	7
4. USABILITY.....	8
5. INSTRUCTION FOR USE.....	8
6. PRINTER FUNCTIONS.....	13
7. SETTING SETUP.....	14
8. ERROR MESSAGES.....	15
9. MAINTENANCE AND ASSISTANCE.....	16
10. SCRAPPING AND WASTE DISPOSAL.....	16
11. WARRANTY.....	17
12. TECHNICAL SPECIFICATION.....	18
13. INSTALLATION.....	18
14. CONFORMITY.....	19
15. IDENTIFICATION LABELS.....	19
16. ASSEMBLY-USE MECHANICAL TELESCOPIC HEIGHT ROD (OPTIONAL).....	20
17. THERMAL PRINTER (OPTIONAL).....	22

By choosing the **WUNDER** professional electronic personal scale, you have purchased a high-precision device. For over 40 years, **WUNDER** has been putting its expertise at the service of health. This instrument complies with national standards in force for hospitals, outpatient clinics and nursing institutions with in-patient care, medical class **Im** with measuring function and it is calibrated in accordance with accuracy class **III**.

The instrument is equipped with a dual LCD electronic terminal with triple readout to simultaneously display Weight, Height and BMI.

1. GENERAL RULES



Carefully read this manual before using the instrument as it supplies important indications concerning OPERATING SAFETY AND MAINTENANCE.

WUNDER reserves the right to modify the images in the following manual, only if they are purely aesthetic modifications and do not affect the safety and performance of the instrument, without communicating the updates promptly.

Conventions:

The following symbols have been used in this manual:

	MEDICAL DEVICE IN COMPLIANCE WITH COMMUNITY DIRECTIVE 93/42/EEC		
	INSTRUMENT SUITABLE FOR LEGAL USE, IN COMPLIANCE WITH DIRECTIVE 2014/31/EU AND EUROPEAN STANDARD EN45501		
	INSTRUMENT IN COMPLIANCE WITH NAWI METRIC DIRECTIVE ACCURACY CLASS III 90/384 - 2014/31/UE AND THE EN45501 EU STANDARD		
	ATTENTION! PLACED BEFORE DETERMINING PROCEDURES. COMPLIANCE FAILURE CAN HARM THE OPERATOR OR PATIENT OR DAMAGE THE PRODUCT		
	WASTE DISPOSAL IN COMPLIANCE WITH 2012/19/UE DIRECTIVE		
	TYPE B PARTS SUPPLIED		BATTERY POWER
	INDICATION OF WEIGHT FUNCTIONALITY		INDICATION OF STABLE WEIGHT
	POSSIBLE INTERFERENCES NEAR THE INSTRUMENT		DUAL INSULATION (CLASS II)
	READ THIS MANUAL CAREFULLY BEFORE USING THE INSTRUMENT		
	MANUFACTURER: WUNDER SA.BI. SRL - VIA VECCHIA PER MONZA, 20 - TREZZO S/ADDA (MI), ITALY		

2. SAFETY



ATTENTION!

Operators must read this manual carefully, comply with the instructions it contains and become familiar with the correct use and maintenance procedures of the instrument.

The manufacturer denies all liability for any direct or indirect damage, including loss of profits, or any other commercial damage due to misuse of the product and failure to comply with the instructions given in this manual.

Please refer to the maintenance and service section for information on maintenance and service.

- Retain this manual for consultation and as a help in staff training
- Do not overload the instrument beyond its maximum capacity
- Do not apply loads abruptly.
- Do not press the keys with sharp or pointed objects
- Do not try to open the instrument.
- Do not remove seals from the instrument.
- Do not short-circuit the battery terminals
- Use only the power supply provided by Wunder. Before using it, make sure that the local mains voltage is compatible with the voltage of the adapter shown on the identification plate
- Regularly check the integrity of the instrument's power cord and make sure it does not come in contact with hot appliances
- Make sure that the power cord does not create obstruction hazards
- Unplug the instrument before cleaning it
- Do not place the instrument in water or other liquids

2.1 INTENDED USE

This device is intended to be used to control the weight of the patient who finds it difficult to remain in an upright position for general diagnostic purposes.

It is strictly forbidden to move the instrument while the patient is on it.

Environment of use: hospitals and specialized medical clinics. The installation room must be equipped with an electrical system that complies with the regulations in force. It is recommended to use the device in environments not exposed to magnetic interference.

Personnel destined to use the product: specialized operators and doctors who are aware of all the safety procedures for correct use.

Control and Responsibility: the medical device must be used under the supervision of a qualified doctor or qualified maintenance personnel and periodic checks that are aware of all safety procedures.

Limitations of use: this medical device can only be used as described in this manual

Useful life of the product: 7 years

2.2 MANUFACTURER'S GUIDE AND DECLARATION – ELECTROMAGNETIC IMMUNITY

The electronic scales is scheduled for operation in the electromagnetic environment specified below. The customer and the user should ensure that it is used in that environment

Guide and Statement of manufacturer – Electromagnetic emissions		
Emission test	IEC 60601 Conformity	Electromagnetic environment guidance
RF Emission CISPR11	Group 1	The scale uses RF energy only for its internal function. Therefore, the RF emissions are very low and are not likely to cause any interference in nearby electronic equipment.
RF Emission CISPR11	Class B	The products is suitable for use in all establishments, including domestic establishments and those directly connected to the public low-voltage power supply network that supplies buildings used for domestic purposes.
Harmonic emission IEC 61000-3-2	Class A	
Voltage fluctuations / flicker emissions IEC 61000-3-3	Compliant	

Guidance and manufacturer's declaration - Electromagnetic Immunity		
Immunity test	IEC 60601 Compliance level	Electromagnetic environment guidance
Electrostatic discharges (ESD) IEC 61000-4-2	± 8 kV contact ± 2 kV, ± 4 kV, ± 8 kV, ± 15 kV air	The floors should be made of wood, concrete or ceramic. If the floors are covered in synthetic material, the relative humidity should be at least 30%.
Electrical fast transient / burst IEC 61000-4-4	± 2kV for power supply lines ± 1kV for input/output lines	The power supply should be of the type used typically in commercial or hospital environments.
Surge IEC 61000-4-5	± 1kV line(s) to line(s) ± 2kV line(s) to earth	The power supply should be of the type used typically in commercial or hospital environments.
Voltage dips, short interruptions and voltage variations on power supply input lines IEC 61000-4-11	0% UT for 0,5 cycle 0% UT for 1 cycle 70% UT (30% dip in UT) for 25s 0% UT for 5 s Note: UT is the A. C. main voltage prior to application of the test level	The power supply should be of the type used typically in commercial or hospital environments. If the user requires continued operation, it is recommended that the product is powered from an uninterruptible power supply or a battery.
Power frequency (50, 60 Hz) Magnetic field IEC 61000-4-8	30 A/m	The product power frequency magnetic fields should be at levels of a typical location in a typical commercial or hospital environment.

Manufacturer's guide and declaration - Electromagnetic emissions		
Immunity test	IEC 60601 Compliance Level	Electromagnetic environment-guidance
Conducted RF IEC 61000-4-6	3Vrms 150kHz to 80MHz (for appliances that are not life supporting)	Portable and mobile RF communications equipment should be used no closer to any part of the product including cables, than the recommended separation distance calculated from the equation applicable to the frequency of the transmitter. Recommended separation distance $d = 1.2 \sqrt{P}$ $d = 1.2 \sqrt{P}$ from 80 MHz to 800 MHz $d = 2.3 \sqrt{P}$ from 800 MHz to 2.5 GHz P is the maximum output power rating of the transmitter in watts (W) according to the transmitter manufacturer and d is the recommended separation distance in metres (m). Field strengths from fixed RF transmitters, as determined by an electromagnetic site survey ¹ , should be less than the compliance level in each frequency range ² . Interference may occur in the proximity of equipment marked with the following symbol: 
Radiated RF IEC 61000-4-3	3 V/m 80MHz to 2,7 GHz (for appliances that are not life equipment)	

¹From 80 MHz to 800 MHz is applied the higher frequency range.

²These guidelines may not apply in all situations. Electromagnetic propagation is affected by absorption and reflection from structures, objects and people.

a) The intensity of the field for fixed transmitters such as base stations for radio, mobile and cordless phones and land radio mobile, amateur radio, radio transmitters in the AM and FM and TV transmitters cannot be predicted theoretically with accuracy. To establish an electromagnetic environment due to fixed RF transmitters, it should consider the electromagnetic survey of the site. If the field strength measured at the place where you use the instrument exceeds the applicable level of compliance of the above, the device should be observed to verify normal operations. If you notice abnormal performance, it may take additional measures such as a different orientation of the device or re-locate it.

b) The field strength over a frequency range of 150 kHz to 80 MHz should be less than 3 V/m.

Recommended separation distance between RW02 Scale and mobile RF communications equipment

The scale is intended for use in an electromagnetic environment in which radiated RF disturbances are controlled. The customer or the user of the product can help prevent electromagnetic interference by maintaining a minimum distance between portable and mobile RF communications equipment (transmitters) and the product as recommended below, according to the maximum output power of the communications equipment.

Output power rating of the transmitter (W)	Separation distance according to frequency of transmitter (m)		
	150 MHz - 80 MHz $d=1,2 \sqrt{P}$	80 MHz to 800 MHz $d=1,2 \sqrt{P}$	800 MHz to 2,5 GHz $d=2,3 \sqrt{P}$
0,01	0,12	0,12	0,23
0,1	0,38	0,38	0,73
1	1,2	1,2	2,3
10	3,8	3,8	7,3
100	12	12	23

For transmitters with maximum rated power output not reported above, the recommended separation distance **d** in meters (m) can be calculated using the equation applicable to the frequency of the transmitter, where **P** is the maximum rated power output of the transmitter in Watt (W) according to the manufacturer of the transmitter.

3. INDICATOR

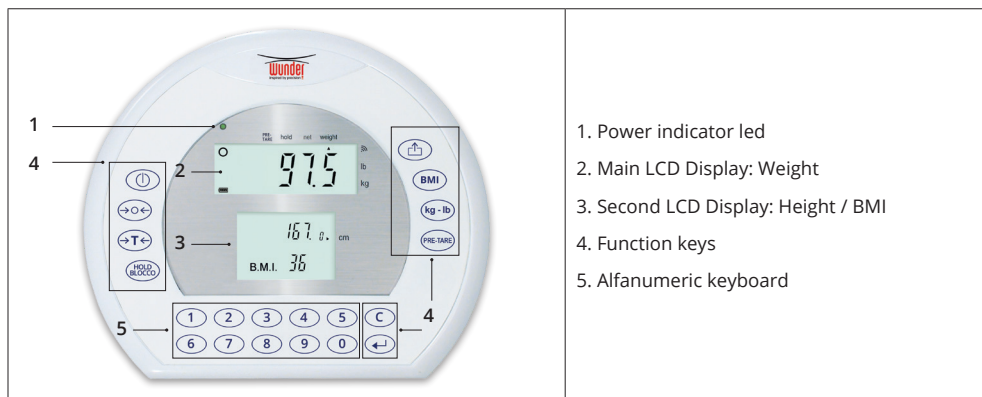

1. Power indicator led
2. Main LCD Display: Weight
3. Second LCD Display: Height / BMI
4. Function keys
5. Alfanumeric keyboard

FUNCTION KEYS

KEY	KEY NAME	DESCRIPTION
	[ON/OFF]	On/Off key. It switches Off the scale if pressed for 3 sec
	[ZERO]	Indication reset (within $\pm 2\%$ of the capacity)
	[HOLD]	Lock of displayed weight / determination of the stable weight value.
	[BMI]	Determine the body mass index (BMI)
	[TARE]	Tare of unwanted weight.
	[CANC]	To delete the incorrect entry during the entering of the digits.
	[ENTER]	To confirm functions
	[PRINT]	Print/send data
	UNIT OF MEASUREMENT	Allows using different units of measurement
	[PRE-TARE]	Allows you to calculate the tare weight, i.e. patient's clothes, by manually setting the value to be subtracted
0-9	[0] ... [9]	Numeric keys

DISPLAY FUNCTIONS

Weight stable: Indicates the weight is stable.

Weight negative: Indicates weight below zero.

Zero: Indicates zero weight.

Flat battery: Indicates the need to recharge or replace the battery.

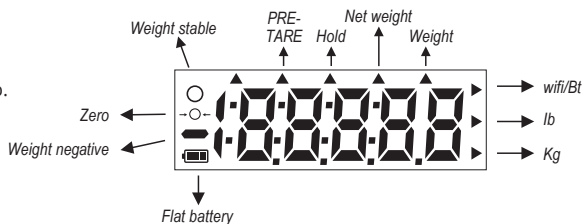

4. USABILITY

1. Make sure to place the instrument on a flat and stable surface away from heat sources, in an environment free of excessive vibrations and air currents.
2. Level the instrument to ensure correct measurement.
3. Connect the instrumentation to the socket with the external adapter supplied.
4. Turn on the balance with the **[ON/OFF]** button and make sure the weight display indicates 0.0kg.
5. Place the patient on the scales' footrest, ensuring that his/her position is stable.
6. Brake the wheels for models RW 02, RW 2.0, RW 3.0, RL, DES, DE 20 and RW-XL.
7. For models with handrails, remove the operator's hands from the supports during weighing to prevent the weight from being altered.

5. INSTRUCTION FOR USE

5.1 TIME SETTING

Keep the **HOLD** key pressed for 3 seconds to access TIME SETTING programming, starting with the flashing digit of the upper line use the numeric keypad to enter the correct data.

Example: programming of 24th May 2021, 8:00 a.m.

	YEAR SETTING: Use the numeric keys to enter the correct value, press HOLD to access the next step once correctly set.
	DATE SETTING (month.day): Use the numeric keys to enter the correct value, press HOLD to access the next step once correctly set.
	TIME SETTING (hours.minutes): Use the numeric keys to enter the correct value, press HOLD to access the next step once correctly set.
<p>Display Format YYYY → MM.DD → HH:SS</p>	

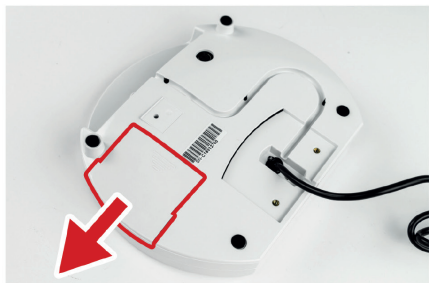
5.2 REPLACE ALKALINE BATTERIES WITH RECHARGEABLE BATTERY KIT (OPTIONAL)

1. Open the battery compartment placed on the back side of the indicator

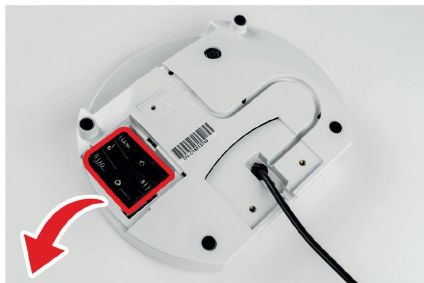

2. Remove the alkaline batteries container carefully

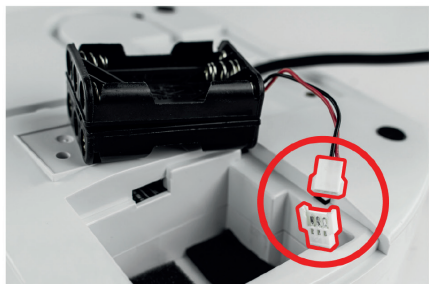

3. Disconnect the connector shown in the figure

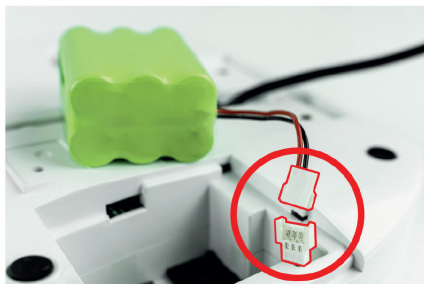

4. Connect the battery pack as shown in the figure



5. Insert the battery pack with the technical text facing upwards and the connector cable on the left. Insert the battery pack first and then gently place the cable in the bottom notch.

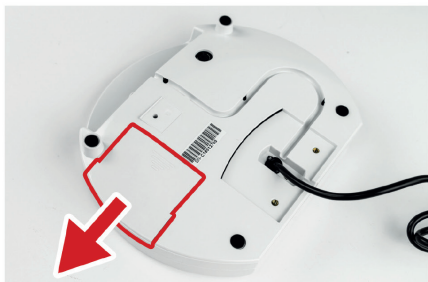

6. Close the battery compartment

5.3 ALKALINE BATTERIES REPLACEMENT

1. Open the battery compartment placed on the back side of the indicator



2. Remove the alkaline batteries container carefully



3. Remove the discharged batteries



4. Insert the new alkaline batteries



5. Insert the batteries container first and then gently place the cable in the bottom notch.



6. Close the battery compartment

5.4 INSTRUCTION FOR CHARGING AND CONNECTING

If **LO** prompt displays on the LCD, please charge the scale with the adaptor.

Plug the adapter on the rear side of indicator.

The battery should be recharged at least every 3 months regardless if it is used or not. After a long period in storage, e.g. over 3 months, the battery should run a full cycle (charge/discharge) to allow it to restore to full capacity.

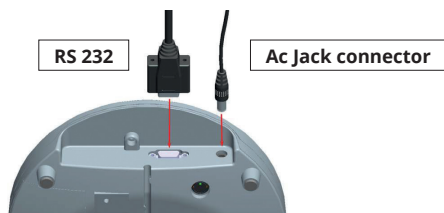

Note: new batteries are supplied partially charged. They must be fully charged before use. In case of prolonged non-use, a complete discharge and recharge cycle should be carried out every 3 months.



ATTENTION!

**FOR PROPER CHARGING OF THE BATTERY PACK,
CONNECT THE INSTRUMENT TO A POWER OUTLET FOR AT LEAST 8 HOURS**

5.5. WEIGHING

Switch on the scale using **[ON/OFF]** key. The diagnostic scale self-check is performed and the software version is displayed. Position the patient on the chair with the feet on the footrest during weighing.

The „0,00 kg“ weight displays on the screen, now the scale is ready for weighing.

Note: If display is not at 0.0kg while switching power on. Kindly press **[ON/OFF]** key to zero the scale which can be used at any time to zero the scale. Press for three second the key **[ON/OFF]**

5.6. HOLD FUNCTION



The scale is provided with the integrated hold function to determine the average weight. It enables people to be weighed accurately although they are not still on the scale platform.

- Switch 'ON' the scale using **[ON/OFF]** key. The diagnostic self-check will be performed and after that „0.0 kg“ will display on the screen with 'stable' and 'zero sign'.
- Move the object/ person on the scale platform.
- Press the **[HOLD]** key once. The 'HOLD' will display on the screen with blinking triangle and after few seconds the average of fluctuating weight will display on the screen and will lock on the display.
- To release the locked weight on display simply press the **[HOLD]** key again and the display will return to normal mode automatically.
- HOLD function can be activated before or after putting the weight on the tread platform. But in case of weighing unstable person it is recommended to press **[HOLD]** key after the person moves on the tread platform.



5.7. FUNCTION kg-lb

This function allows you to switch between weight in kilograms and weight in pounds.

5.8. PRETARA FUNCTION

To calculate the tare weight for the clothes, press the key (PRE-TARE) and use the "0" key to enter the weight. Confirm with (←)	
Use the numeric keypad to enter the weight (e.g: 2 kg) Confirm with (←)	
The subtracted weight appears on this page of the display. The patient can now be weighed.	

5.9 BMI FUNCTION

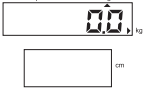
Long press [BMI] in weighing mode. The secondary display shows the last set height, with the left digit flashing.	
Use the number keypad to enter the height (e.g.: 170 cm) Confirm with [ENTER]	
Press [BMI] to lock the value. Climb onto the weighing platform when the display shows "HOLD" and weigh yourself. The scale shows the weight, height and BMI index.	
Press [BMI] again to release the memorized weight and go back to normal operation mode.	

5.10 MEANING OF BODY MASS INDEX (IMC)

The Body Mass Index (BMI, kg/m²), or Quetelet index, calculated by dividing the weight expressed in kg by the square of the stature expressed in meters, is the weight index most used in adults (World Health Organization, 1995; World Health Organization, 1998) as an expression of "correct" weight for stature.

To be calculated as: $WEIGHT (kg) / HEIGHT (m)^2$

Reference values (men and women)		
Clinical condition	IMC (kg/m ²)	
Severe malnutrition	<16	Underweight
Moderate malnutrition	16-16.9	
Mild malnutrition	17-18.4	
Normal weight	18.5-24.9	Normal weight
Overweight	25-29.9	Overweight
1 st degree obesity (mild)	30-34.9	Obesity
2 nd degree obesity (moderate)	35-39.9	
3 rd degree obesity (severe or morbigena)	≥40	

5.11 TARE FUNCTION

Tare allows the user to zero the instrument to cancel the weight of a container/ clothes from the reading of the instrument, thus giving the true weight of the product/ person being tested. Turn on the scale using [ON/OFF] key.

When the display shows  on the screen and scale beeps twice, then place the object (clothes) need to be tare on the tread platform.

Press [TARE] after the weight stabilizes and stable sign appears on the display. Display will return to . Place the to be weighed (without removing the tare object). The weighing result is the Net weight.

To delete the saved tare value, remove the tare object from the tray and press [TARE] key again.

6. PRINTER FUNCTIONS

Weight can be printed for records using RS232 interface cable. After weighing simply press [PRINT] key to print out the results.

The format presented below is the standard format of results print-out and cannot be changed.

The print format (not editable) is shown on the right

More informations info@wunder.it or service@wunder.it

```

WUNDER
-----
Modello           WU150
Numero di serie   C12345678
Data/Ora          01/01/2000 12:00
-----
Peso              20.0 kg
Altezza           130.0 cm
Indice Massa Corporea  11.8
Sottopeso         <18
Normopeso         18-24.9
Sovrappeso        25-29.9
Obesità classe I   30-34.9
Obesità classe II  35-39.9
Obesità classe III >40
    
```

```

WUNDER
-----
Model            WU150
S/N:             C12345678
Date/Time        01/01/2000 12:00
-----
Weight           20.0 kg
Height           130.0 cm
BMI (Body Mass Index)  11.8
Underweight      <18
Normal weight    18-24.9
Pre-obesity      25-29.9
Obesity class I  30-34.9
Obesity class II 35-39.9
    
```

RS232 Interface parameteres (not editable):

- Baud rate: 9600 bps
- Parity check: None
- Data length: 8 bits
- Stop bit: 1 bit
- Handshake: RTS / CTS
- Data code: ASCII

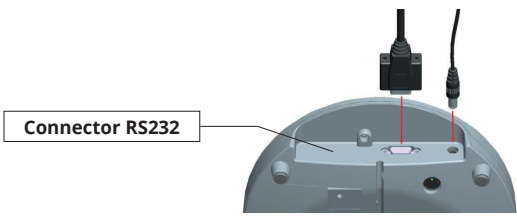

Serial RS232

Connecting with PC

Start Hyper Terminal program from clicking

Start Menu → Programs → Accessories → Communication → Hyper Terminal.

New Connection Description

Give new connection a name then click OK.

Select Your COM Port

Click Connect to select your COM port. Usually there's only one option for select. Then click OK.

Port Settings

Click Bits per second to set up rate at 9600, Data bits at 8, Parity at None, Stop bits at 1 and Flow control at Hardware. Then click OK to complete your setting.

Output Data

When press the PRINT key to output data from scale to PC or an Optional Printer.

PIN	Signal
2	TX
3	RX
5	GND

7. SETTING SETUP

Switch ON the indicator and press **[ZERO]** key for 3 seconds, display shows "SETUP" and after "A.OFF".

[TARE] = ▼ go to the next function

[HOLD] = ► enter and edit parameters

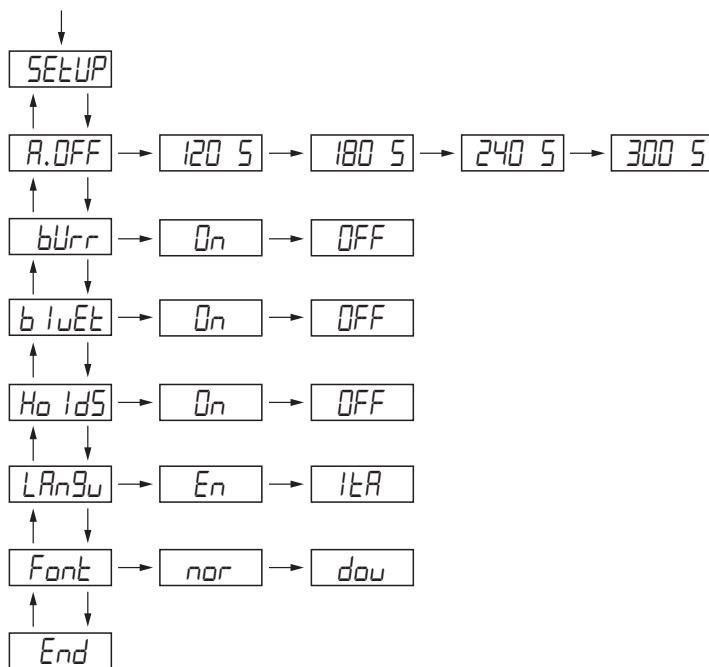

When the display shows "End" press **[HOLD]** key to confirm settings.

A.OFF: Instrument auto-off time: 120 sec, 180 sec, 240 sec, 300 sec, Off

bUrr: Enable or not beep (acoustic signal) operation: On/Off

bLUeL: Setting Bluetooth

Ho ldS: Setting Hold

LRnGw: Setting print language

Font: Setting print font

8. ERROR MESSAGES

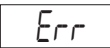
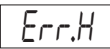
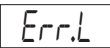
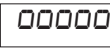
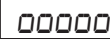
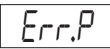
ERRORS	DESCRIPTION	SOLUTION
	Low battery: The voltage of the battery is too low for operate	Please replace the battery with a new one or plug the adapter.
	Overload: The load exceeds the maximum capacity of the scale	Please reduce the load and try again.
	Counting error (high): The signal from the load cell/s is too high	Error normally caused by a serious fault of the scale (load cell or wiring). Please contact the local technical service.
	Counting error (low): The signal from the load cell/s is too low	Error normally caused by a serious fault of the scale (load cell or wiring). Please contact the local technical service.
	Zero count over calibration zero range +10% while power ON	Please re-calibrate the scale.
	Zero count under calibration zero range -10% while power ON	Please re-calibrate the scale.
	Error EEPROM: indicates an error with software of the scale	Error normally caused by a serious fault of the scale (load cell or wiring). Please contact the local technical service.

9. MAINTENANCE AND ASSISTANCE

For better and longer duration of the product it should receive thorough general cleaning periodically. The instrument must be cleaned with a soft cloth moistened with water or neutral detergent, without using solvents or abrasive substances. If the instrument remains idle for a long period, remove the batteries from the terminal. During shipping, make sure not to subject the instrument to blows or excessive mechanical stress. In case of repairs or assistance, contact your dealer or an authorised service centre contacting service2@wunder.it or sales@wunder.it

10. SCRAPPING AND WASTE DISPOSAL

If set aside for a long period, protect those parts which could be damaged due to dust build-up.

Scrapping: When you decide to no longer use this item, we recommend making it unusable. We also recommend making those parts which could be sources of danger harmless.



Waste disposal 2012/19/UE

This product complies with the **Directive 2012/19/UE**. The symbol of the crossed-out waste bin on the appliance indicates that the product, needing to be treated separately from household waste, at the end of its useful life must be completed in a separate collection facility for electric and electronic appliances or returned to the dealer upon purchase of a new equivalent appliance. The user is responsible for bringing the appliance to an appropriate collection structure at the end of its life. Appropriate separate collection and sending the appliance for recycling, treatment and environmentally compatible waste disposal contributes to avoid possible negative effects on the environment and health and favours the recycling of the materials the product is made of.

For more detailed information regarding available collection systems, contact your local waste disposal service or the shop where the product was purchased.

As consumers, you are obliged by law to return used or dead batteries. You may deposit old batteries at public collection spots in your town or else with any battery dealer who has placed specific collectors for this purpose. Even when scrapping electric and electronic appliances, they must be removed and deposited in specific collectors.

NOTE: The following symbols indicate the presence of harmful substances.

Pb Pb = containing Lead	Cd Cd = containing Cadmium	Hg Hg = containing Mercury
--------------------------------	-----------------------------------	-----------------------------------



ATTENTION!

**Do not throw electric parts and used batteries away with household waste.
Dispose of the batteries by means of your closest collection centres.**

11. WARRANTY

This certificate must be kept until the warranty has expired.

It must be presented together with the invoice, tax receipt or delivery note providing the name of the dealer and date of purchase whenever a technical intervention is required. Otherwise the user will lose any warranty rights. The warranty takes effect from the date of purchase and is valid during the entire period foreseen by the current catalogue/pricelist.

By warranty we mean the replacement or repair free of charge of parts making up the appliance which, at the discretion of the manufacturer, are deemed faulty from the origin; Wunder therefore has the faculty of repairing or replacing the item.

The warranty does not cover:

- shipping faults, damage caused by falls, carelessness or tampering.
- damage caused by incapability of using the appliance and of its improper use.
- damage caused by an insufficient or inadequate electrical system or alterations resulting from environmental, climatic or other types of conditions.
- damage due to incorrect installation of the appliance and repairs carried out by unauthorised personnel.
- Interventions at home for convenience controls or presumed defects.
- Routine maintenance and that which can be considered normal wear from use.
- consumables such as: power supplies, batteries, keyboards, plates, wheels, heads, rolls, load cells faulty due to blows or overloads.

Service can also be refused when the appliance has been changed or transformed in any way.

In case of interventions at one's home, the customer must pay the fixed fee; if however the appliance is repaired at an authorised Wunder Service Centre, expenses and relative travel risk are borne by the user.

Wunder will not be held liable for damage of any nature caused directly or indirectly to persons, animals or objects resulting from failure to comply with all the instructions indicated in this manual or anyway resulting from improper use.

The Court of Bergamo has jurisdiction in case of any dispute.

12. TECHNICAL SPECIFICATION

Model	RB pole	RB-L	RB with cable
Capacity	250kg	250kg	250kg
Division	50-100g	50-100g	50-100g
Manufacturer	Wunder Sa.bi. srl Trezzo S/Adda Milano Italy		
MDD OIML	Class III		
Unit weight	Kg		
Display	Double LCD: 1 LCD 20mm weight with 5 active digits; 2 LCD height and BMI 12mm		
Function Key	ON/OFF, HOLD, BMI, TARA, CANC, ENTER, PRINT		
Power	Adapter 12 V - 2 A Rechargeable Batteries Pack- (OPTIONAL)  use only stabilized adapter from Wunder		
Operation temperature	from 5°C to 35°C		

13. INSTALLATION

Verification of equipment:	
Model RB Column 1. Scale base with column support 2. Column and display: already connected 3. External power supply unit 4. Instructions Manual 5. Height measuring telescopic rod (optional not included see paragraph15)	Model RB-L; RB CABLE 1. RB-L: Display fixed to the base 2. RB CABLE: Base and display connected via 2 metre cable 3. External power supply unit 4. Instructions Manual





ATTENTION!

ONLY FOR COLUMN SCALE

After removing the instruments from the packing check the integrity and right contents.
 Put the scale far from source from of heat e vibration. Put the scale on stable surface.

Assembly:

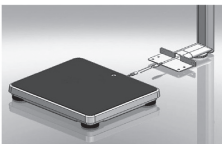
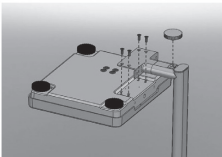
Assembling column to the platform:

 <p>1</p>	<ol style="list-style-type: none"> 1. Connecting wire between column and platform first 2. Flip the scale platform on the bench 3. Fix with 4 screw the column at the platform 4. Place to the ground the scale and adjust the 5 adjustable feet. 5. Then make sure that the bubble inside the spirit level is as shown in image 4, otherwise repeat point 4. 6. For use connect the external power supply with the electric current.
 <p>2</p>	
 <p>3</p>	
 <p>4</p>	



14. CONFORMITY

<p>WUNDER PROFESSIONAL ELECTRONIC SCALE MODEL: RB SERIAL N°.....</p>
<p>We hereby certify that this instrument has been inspected and has successfully passed the functional test. It complies with the following standards and directives:</p>
<p>EN 45501 / EN60601-1-2 / EN60601-1 93/42/EEC – Medical Devices Directive</p>

15. IDENTIFICATION LABELS



The applied metrological plate indicates the year of manufacture, e.g. M 19 = 2019, **M 20 =2020**... and so on.

 <p>Manufacturer: Wunder Sa.Bi. Srl Via vecchia per Monza, 20 20056 Trezzo sull'Adda (MI) Italy</p> <p>Model: RB (WU150) Max = 150/250 kg e = 50/100 g Min = 1 kg T = -250 kg +5 °C / +35 °C</p> <p>CE M 21 0474 T12037 REV 0 MATR.0000</p>	<p>WUNDER Sa.Bi.S.r.l.</p> <p>Model: RB (WU150) 12V 2A</p> <p>Internally powered via battery or externally powered by model UE24WV-120200SPA</p> <p>Internamente alimentata con batteria o alimentata esternamente da modello UE24WV-120200SPA</p> <p style="text-align: right;">MATR.0000</p> 
<p>RB (WU150) Vano Batterie</p> <p>Vedere il manuale di istruzioni per la sostituzione della batteria (modello ricaricabile tipo: RETC 7,2V 2000mAh)</p> <p>Consult the user manual to replace the battery (rechargeable model type: RETC 7,2V 2000mAh)</p>	<p>IN ACCORDANCE WITH 93/42 EEC CONFORME ALLA DIRETTIVA 93/42 CEE</p> <p>CE 0476</p>

16. ASSEMBLY-USE MECHANICAL TELESCOPIC HEIGHT ROD (OPTIONAL)

 **ATTENTION!**
Only for column scale

16.1 FIXING MECHANICAL OR ELECTRONIC STATIMETER

Figure 1a: the instrument in the packaging is presented with the support statimeter already mounted (screwed screw in the holder). It is only necessary to fix the statimeter to the black ABS support

Figure 1b: statimeter fix the measurement height to the support in black abs with the supplied screw.

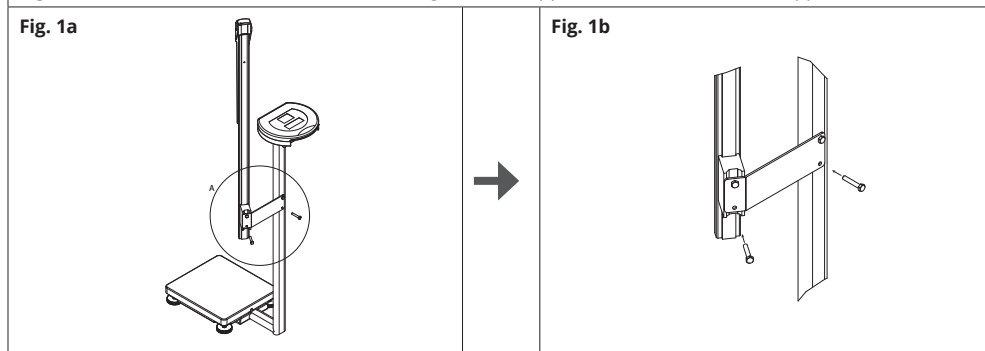

16.2 USE OF MANUAL MECHANICAL STATIMETER

 **ATTENTION!**

FOR THE MEASUREMENT OF HEIGHT THE PATIENT MUST BE ON THE SCALE PLATFORM

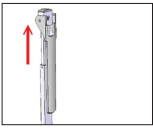
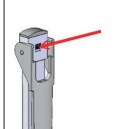
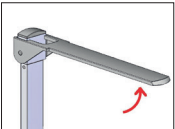
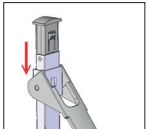
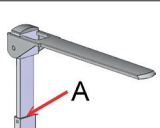
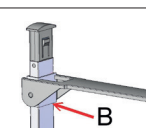
Measurements more than 130 cm		Measurements less than 130 cm	
<p>1</p> 	<p>Pull up the height meter rod.</p>	<p>1</p> 	<p>Lower the headrest palette and press the black center stopper.</p>
<p>2</p> 	<p>Position it horizontally.</p>	<p>2</p> 	<p>Holding down the black stop, lower the headrest palette.</p>
<p>3</p> 	<p>Lower the rod up to the point where the lever rests head touches the patient's head. The height can be read at the point 'A'.</p>	<p>3</p> 	<p>Lower the rod to the point where the blade touches the patient's head. The height can be read at point 'B'.</p>

16.3 ASSEMBLE DIGITAL HEIGHT ROD (OPTIONAL)

STEP 1: INSTALLATION ALKALINE BATTERY

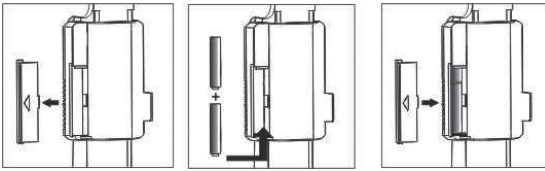

- a. Removing battery cover at the rear of indicator
- b. Installing code AAA batteries * 2
- c. Reinstalling the battery cover

STEP 2: CONNECTING CABLE DIGITAL TELESCOPIC HEIGHT METER

To use the digital height rod, a cable is provided to connect the height rod directly to the display and obtain the height measurement automatically.

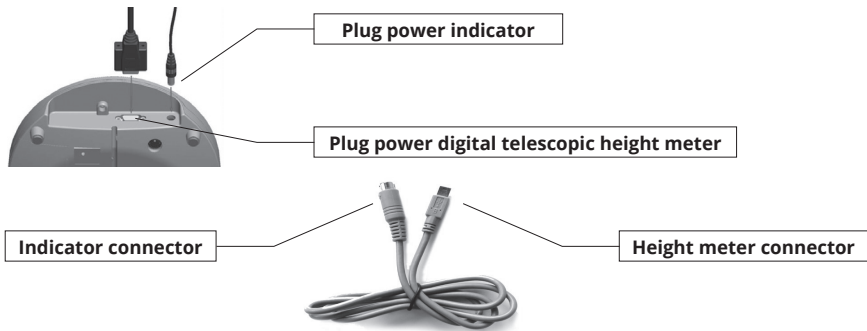

The indicator connection is under indicator
 The height meter connection is under indicator height meter

STEP 3: MEASURING HEIGHT

THE MEASUREMENT OF THE PATIENT MUST BE GETTING ON THE PLATFORM OF SCALE

16.4 USE DIGITAL TELESCOPIC HEIGHT ROD

Steps to accurate measurement

- Make indicator move to the end of measuring rod. Then switch ON and press reset key once to calibrate.
- Push the head stop far enough up the rod so that the person to be measured can stand underneath it comfortably.
- Ask the person to be measured to stand with his or her back to the rod.
- Sliding the head stop down until it touches the head.
- Read the height measured on the display unit.

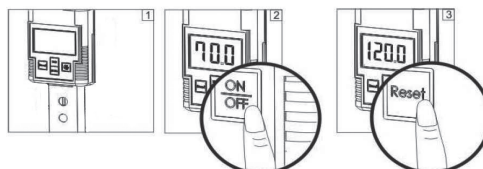

17. THERMAL PRINTER (OPTIONAL)



Read this manual carefully before using the instrument

Platen Rollen

Roll Holder

Tear Bar

Printer Button

Status Indicator

RS 232 connect

Power (Adattatore)

ON/OFF

SHOCK HAZARD WARNING

The printer and power supply should never be operated in a location where either one can get wet. Personal injury could result.

MEDIA WARNING

Always use high quality approved paper print roll. The approved product can be ordered from your dealer.

RELOADING HINT

If printer runs out of paper roll while printing, switch the power off and reload paper roll. Power on and print again.

17.1 HOW TO USE YOUR PRINTER



Connect the AC Adaptor and RS232 interface cable.
The PRINTER can be connected via the RS232 port and cable with the RB.



Press the **I/O** button to power on the printer.

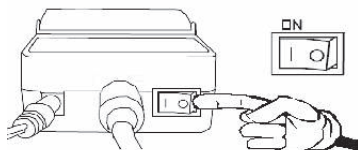

Press the **PRINT** key: Print double language

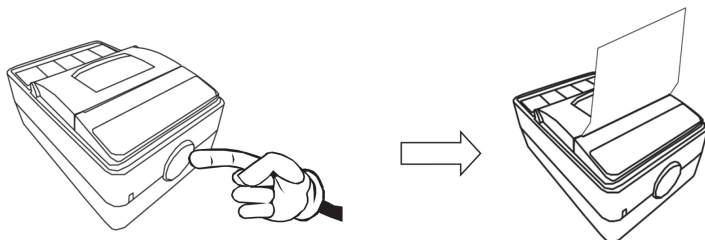

17.2 CHANGING THE PAPER ROLL

The paper print roll on a PRINTER XL printer is changed as follows:

1. Open the upper cover and position the paper roll so that it feeds in the right direction.

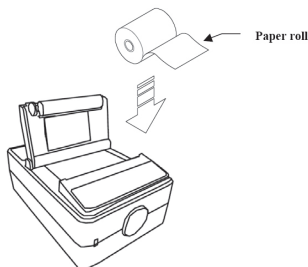

2. Feed the end of the paper roll through the printer cover and close the cover. The printer is ready to print.

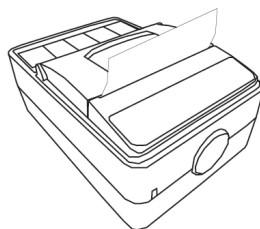

17.3 PRINTER SPECIFICATION

ITEM	SPECIFICATION
Printing method	Thermal dot line printing
Resolution (dots/mm)	8 dot/mm
Printing width (mm)	48 mm
Max. paper thickness (µm)	80µm
Paper	57.5±0.5 mm (W) x ψ30mm max
Paper loading	Easy loading
Printing speed (mm/s)	75 mm/s
Dimensions (L x W x H)	120 x 80 x 50mm
Operating temperature (□)	0°~ 50°C
Operating humidity (%)	20% to 85% (no condensation)
Interface	Conform to RS232
Voltage range (adaptor only)	12V 2A

17.4 ERROR MESSAGES

PROBLEM	SOLUTION OR REASON
Status Indicator does not light when power switch is turned to ON (I) position.	Check the power connections from AC outlet to the printer power supply.
Status indicator illuminated (green light), but the printer will not print.	Check interface cable connections from the scale to printer. Make sure the top cover is closed and locked.
Printer paper jammed.	Reset the paper roll. Please refer to "CHANGING THE PAPER ROLL".
Status Indicator is flashing green.	Paper roll is out. Reload a new source of paper roll so the printer can continue printing. Please refer to "CHANGING THE PAPER ROLL".

**Manufacturer's Declaration of Conformity**

This product has been manufactured in accordance with the harmonized European standards, following the provisions of the below stated directives:
Electro Magnetic Compatibility Directive 2004/108/EC
Low Voltage Directive 2006/95/EC

only Medical Approval Scale is in conformity with
Medical Directive 93/42/EEC

FCC CLASS B Declaration of Conformity

This device complies with the limits for a Class B digital device, pursuant to Part 15 of the FCC Rules